

DO NOT SCALE - IF IN DOUBT ASK

1ST ANGLE PROJECTION

DIMNS IN MM

PROGRAM No:-

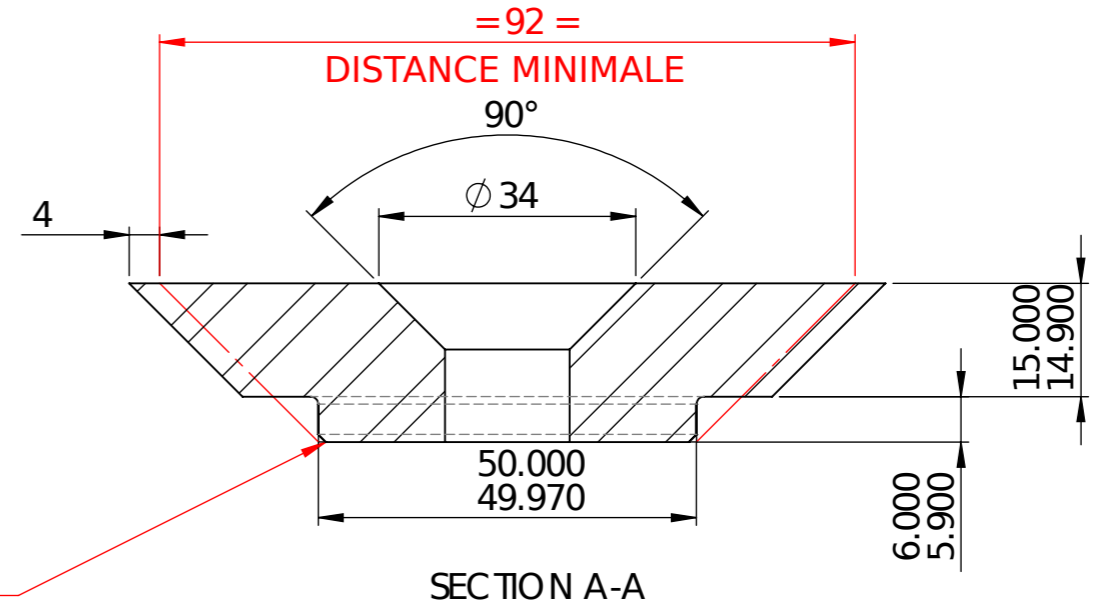
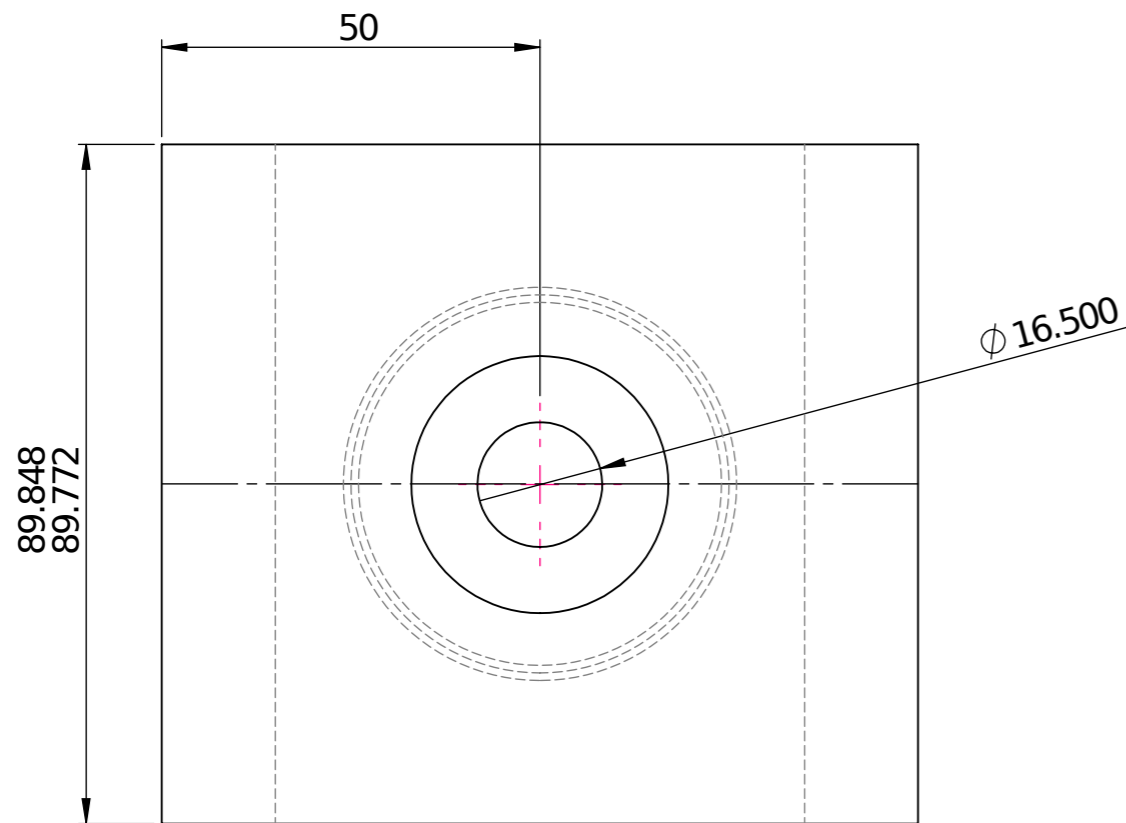
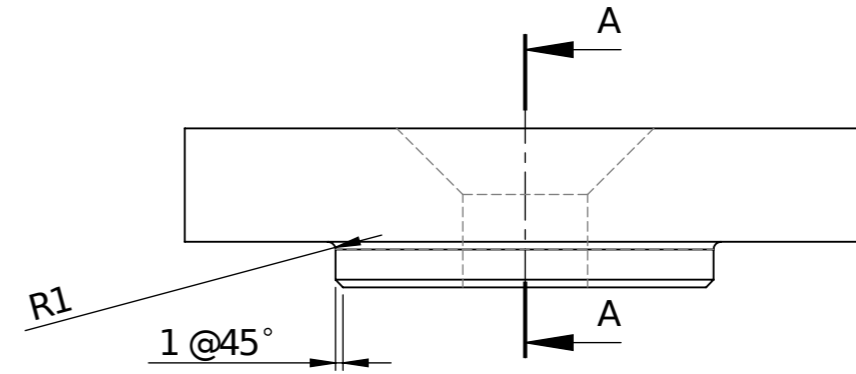
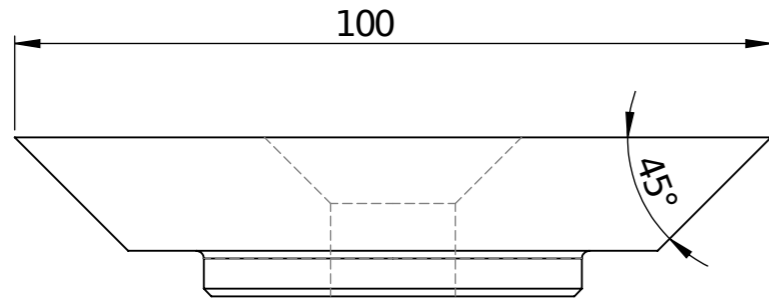

NE PAS ALTERER
CE BORD

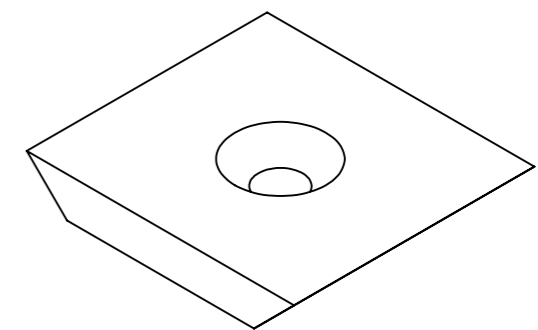
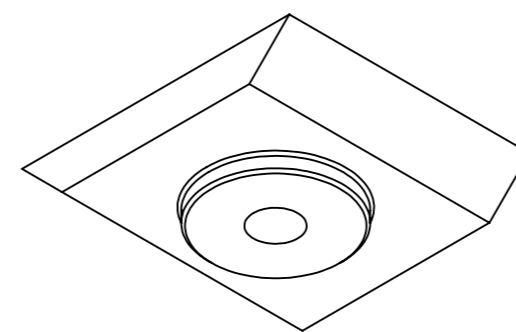

TOLERANCES: LINEAR: 0.025MM ANGULAR: 0.25°	FINISH: Harden & Temper to 53-55RC	NAME	QUANTITY	DATE	DEBUR AND BREAK SHARP EDGES	TOLERANCES MACHINED PARTS +/- 0.025mm FABRICATED PARTS +/- 1.0mm
		DRAWN	RVMR	03/03/2017		
		CHK'D	BGG			

GreenMech Ltd
 The Mill Industrial Park
 Kings Coughton
 Alcester
 Warks B49 5QG Tel 01789 400044

Material & Thickness
 D2 Tool steel

TITLE:
QUAD CUTTER

WEIGHT:

DWG NO.
 QC2030-2-37-2 GRINDING

A3

REV	MODIFICATION	DRN	APPD	DATE
1				
2				
3				

SCALE:1:1

SHEET 1 OF 1